



	Fresh Water	Pool Water	Sea Water	220-240 V	400 V	110-120 V	50 Hz	60 Hz	12 V AC	24 V DC	DMX	DMX/RDM	Plug and Spray
ProfiLux LED 110	✓	✓	✓	✓	✓	✓	✓	✓	✓	✓	✓	✓	✓

PROFILUX LED 110/DMX/02

The ProfiLux LED 110/DMX/02 is the new, tiny, compact and powerful RGB-LED light with 213 lumen and a beam angle of 25°.

The compact LED-light ($\varnothing = 75.2$ mm) has a high quality stainless steel housing and is suitable for fresh water, pool water and sea water application (for definition see page 232). Equipped with a temperature control and a thermal protection, the LED light can also be installed dry. The lifetime of these lights is up to 100,000 h.*

The light is supplied with a bracket for ground installation as well as for nozzle tube mounting (designed for socket 10 (51018)). The RGB-LED light has a 1 mtr. long connecting cable with a waterproof hybrid (power/data) connector. The ProfiLux LED light can be controlled via DMX with the underwater LED Driver/

DMX/02 (50720) (not in scope of supply). The basic colours of the LED-RGBW-lights are measured individually for their brightness. The LED-Driver ensures equal brightness for all lights in the system, thereby creating a homogeneous colour combination.

Product characteristics at a glance

- Energy efficient LED-RGB-light with bracket for ground installation and nozzle tube mounting.
- 213 Lumen with a beam angle of 25°, max. 6 Watt
- Temperature controlled high quality LED for an extra-long life of up to 100,000 h.*
- Wet and dry installation – water proof in accordance with IP68
- For fresh water, pool water and sea water
- External electronic in a separate control box / junction box – waterproof connector, easy to connect.
- DMX/RDM-capable in combination with the Underwater LED Driver/DMX/02 (50720)
- Individual measurement of the basic colours of the LED-RGBW lights and the use of the Underwater LED Driver/DMX/02 (50720) guarantees equal brightness of all lights in the system and a homogeneous colour combination.
- Galvanic isolation between the DMX and 24V DC power
- Stroboscope effect

*In case of underwater application, an intelligent heat management and quality LED enables a lifetime of up to 100.000 hrs. This claim does not entitle to a guarantee.

INNOVATION – MADE BY OASE



ProfiLux LED 110/DMX/02

The variety of colour combinations and the stroboscope effect reveal their full effect in combination with dynamic water effects which can be generated, for eg., with the Vario-Switch or the Varionaut pumps. Together, they create completely new compositions on open spaces and in fountains.

The Underwater LED Driver/DMX/02 (see page 148) is required for a DMX/RDM-capable application of the ProfiLux LED light. In addition a RDM-capable controller, like WECS II (WECS II 512, WECS II 1024 or WECS II 2048, see page 156-165), is also needed.

The ProfiLux-LED light has a 1 mtr. long connecting cable with a hybrid connector for connecting it to the Underwater LED Driver/DMX/02. A 3.0 mtr. or 7.5 mtr. hybrid extension cable per light can be used for extending the connection

(see page 146). Up to 4 LEDs can be individually controlled with this external Underwater LED-Driver. The Underwater LED Driver/DMX/02 is equipped with two connection boxes – one for the power supply with 24V DC and the other one for a DMX/RDM-data cable. The special connection technology makes a watertight pluggable cabling possible.

The use of the hybrid connection box can lead to an economic advantage of the system. The lights which are connected to the hybrid box always have the same colour. (see system diagram.)

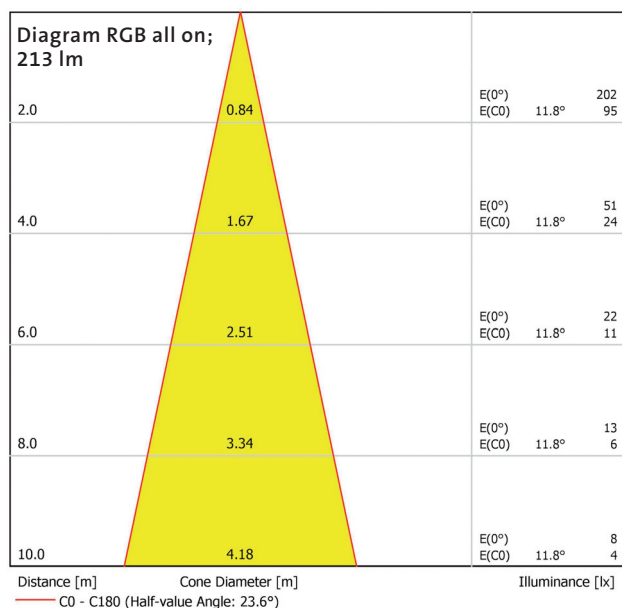

Accessories (must be ordered separately)

Extension cable hybrid / 3.0 m (see page 146)	50728
Extension cable hybrid / 7.5 m (see page 146)	56403
Hybrid connection box (see page 146)	56404
Underwater LED Driver (see page 148)	50720
Connecting cable DMX/01 (see page 144)	Order no.
Connecting cable DMX/1.0 m/01	12368
Connecting cable DMX/3.0 m/01	12369
Connecting cable DMX/5.0 m/01	12371
Connecting cable DMX/10.0 m/01	12372
Connecting cable DMX/20.0 m/01	12373
End Resistant for Bus-System DMX/01	12007
Connecting cable 24V DC/01 (see page 142)	Order no.
Connecting cable 24V DC /1.0 m/01	12762
Connecting cable 24V DC /3.0 m/01	12552
Connecting cable 24V DC /7.5 m/01	12553
Connecting cable 24V DC /15.0 m/01	11720
PowerBox 24 V DC / 01 (see page 143)	50493
Underwater power supply 250 / 24 V / 01 (see page 152)	50733
WECS II 512 (see page 156)	56491
WECS II 1024 (see page 156)	56492
WECS II 2048 (see page 162)	56507

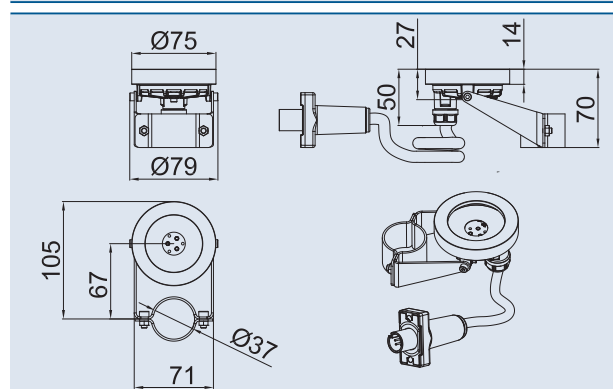
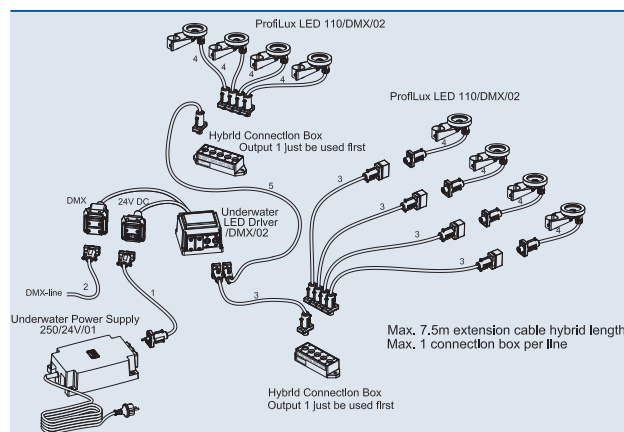

DMX-Channel	Function
Channel 1	red
Channel 2	green
Channel 3	blue
Channel 4	strobe

ProfiLux LED 110/DMX/02		
Luminous flux all on	[lm]	213
Luminous flux red	[lm]	64
Luminous flux green	[lm]	114
Luminous flux blue	[lm]	35
Beam angle	[°]	25 (± 2)
Strobe effect	[Hz]	25
Energy efficiency category		A
Weighted energy consumption [kWh/1000h]		6.6
Rated voltage	[V/DC]	24
Power consumption	[W]	6
Rated current	[A]	0.26
Dim frequency	[Hz]	2800
Power connection type		Hybrid plug
Cable length	[m]	1
Protection class		IP 68
Dimensions (Ø x h)	[mm]	75.2 x 70
Material		Stainless steel 1.4404 (AISI 316L)
Weight	[kg]	0.48
Order no.		56267